

## 300EH Series Horizontal Die Grinders (Collet Output)

**New Tools!!**

### 300EH Series



**New Longer Length**

**New Shorter Length**

Collet Type/Capacity	Extension Length	Rated Speed	Lever Style	MODEL NUMBER
ER Style Insert Collet 1/4 Inch or (6 mm) Maximum	+3	30000 RPM	Standard Lever	300EH+3;30000;1/4
			Safety Lever	300EHK+3;30000;1/4
		25000 RPM	Standard Lever	300EH+3;25000;1/4
			Safety Lever	300EHK+3;25000;1/4
	+6	30000 RPM	Standard Lever	300EH+6;30000;1/4
			Safety Lever	300EHK+6;30000;1/4
		25000 RPM	Standard Lever	300EH+6;25000;1/4
			Safety Lever	300EHK+6;25000;1/4
	+8	30000 RPM	Standard Lever	300EH+8;30000;1/4
			Safety Lever	300EHK+8;30000;1/4
		25000 RPM	Standard Lever	300EH+8;25000;1/4
			Safety Lever	300EHK+8;25000;1/4

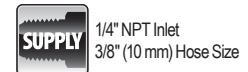
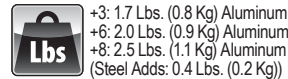
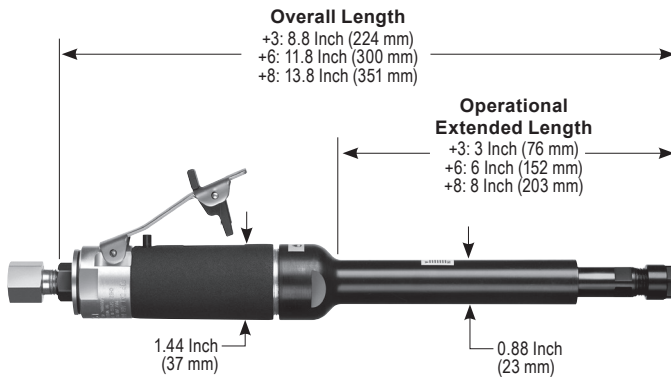

#### STANDARD EQUIPMENT

- Tool
- Operating Instructions and Service Manual
- Wrenches (sizes based on options)

#### 300EH Series Alternate Options

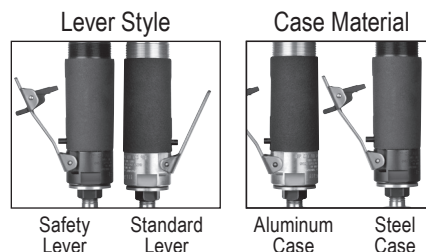

#### Inserted Tool Mounting

